

Specifications

Model	SX-150	
Measurements	Metric	US
Working height maximum*	48.33 m	158 ft
Platform height maximum	46.33 m	152 ft
Horizontal reach maximum	24.38 m	80 ft
Below ground reach	0.61 m	2 ft
A Platform length	0.91 m	3 ft
B Platform width	2.44 m	8 ft
C Height - stowed	3.05 m	10 ft
D Length - stowed	16.18 m	53 ft 1 in
Length - transport (jib tucked under)	13.00 m	42 ft 8 in
E Width - axles retracted	2.49 m	8 ft 2 in
Width - axles extended	5.03 m	16 ft 6 in
A Wheelbase - axles retracted	5.03 m	16 ft 6 in
Wheelbase - axles extended	4.72 m	15 ft 6 in
G Ground clearance - center	0.38 m	1 ft 3 in

Productivity

Lift capacity	340 kg	750 lbs
Platform rotation	160°	160°
Vertical jib rotation	135°	135°
Turntable rotation	360° continuous	
Turntable tailswing - axle retracted	1.14 m	3 ft 9 in
Turntable tailswing - axle extended	1.06 m	3 ft 6 in
Horizontal jib rotation	60°	60°
Drive speed - stowed	3.7 km/h	2.3 mph
Drive speed - out of stowed		
below 38.10 m (125 ft)	0.65 km/h	0.4 mph
above 38.10 m (125 ft)	0.17 km/h	0.1 mph
Gradeability - stowed**	35%	35%
Turning radius - axle retracted: inside	6.28 m	20 ft 7 in
outside	8.56 m	28 ft 1 in
Turning radius - axle extended: inside	3.02 m	9 ft 11 in
outside	7.34 m	24 ft 1 in
Controls	12 V DC proportional	
Tyres	445/65D 22.5 18 ply foam-filled	

Power

Power source	Deutz Stage IIIA TD 2011 L04i 4-cylinder, 55 kW (74 hp), oil cooled Deutz Stage IIIB TD 2.9L4 4-cylinder, 55 kW (74 hp), water cooled Perkins 804-33T 4-cylinder turbo diesel, 55 kW (74 hp)	
Auxiliary power unit	12 V DC	12 V DC
Hydraulic tank capacity	416 L	110 gal
Fuel tank capacity	189 L	50 gal

Weight***

4WD	22,657 kg	49,950 lbs
-----	-----------	------------

Standards Compliance

EU Directives: 2006/42/EC - Machinery Directive
Harmonized Standards: EN280;
2004/108/EC (EMC); 2000/14/EC (Outdoor Noise)

Range Of Motion SX-150

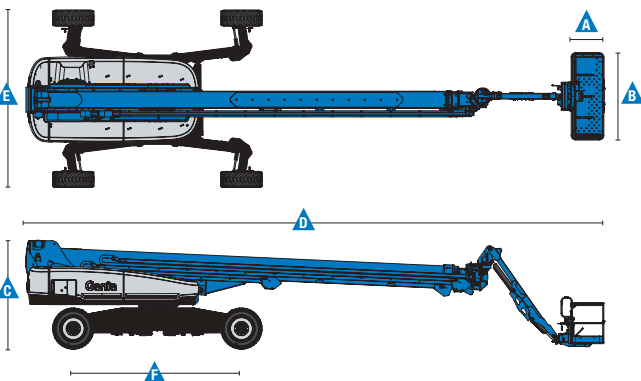
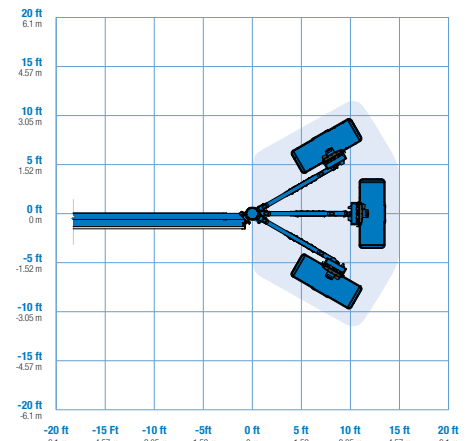
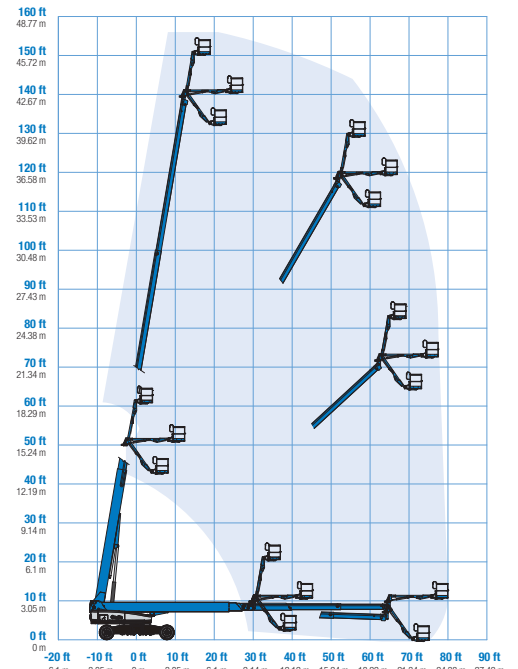

* The metric equivalent of working height adds 2 m to platform height. U.S. adds 6 ft to platform height.

** Gradeability applies to driving on slopes. See operator's manual for details regarding slope ratings.

*** Weight will vary depending on options and/or country standards.

Features

Standard Features	Easily Configured To Meet Your Needs	Options & Accessories
-------------------	--------------------------------------	-----------------------

Measurements

SX-150

- 48.33 m (158 ft) working height
- 24.40 m (80 ft) horizontal reach
- 340 kg (750 lb) lift capacity

Productivity

- X-chassis™ extendable axles
- Self-leveling platform
- 160° Hydraulic platform rotation
- 3.05 m (10 ft) rotating jib
- Proportional joystick controls
- Hydraulic oil cooler
- Thumb rocker steering
- Drive enable
- AC power to platform
- Horn
- Hour meter
- Tilt alarm
- Descent alarm
- Alarm package
- 360° continuous turntable rotation
- Positive traction drive
- Two speed wheel motors
- Four wheel high angle steer
- Four steering modes: front, rear, crab and coordinated
- Four wheel brakes
- Ground control box cover
- Engine status display
- Welder Ready package
- Certified load sensor
- Telematics-Ready Connector
- Lift Guard™ Contact Alarm

Power

- All engines are emissions compliant
- 7.5 kW generator
- 415V/240V/50Hz (Europe)
- 110V/55V/50Hz (UK)
- 12 V DC auxiliary power
- Anti-restart engine protection
- Auto engine fault shutdown
- Intake air heater (Deutz engine)

Platform Options

- Steel 2.44 m (8 ft) (standard)
- Steel 2.44 (8 ft) tri-entry

Engine Options

- Deutz Stage IIIA diesel 55 kW (74 hp), oil cooled
- Deutz Stage IIIB diesel 55 kW (74 hp), water cooled
- Perkins diesel 55 kW (74 hp), water cooled

Drive/Steer

- 4 x 4 (standard)
- 4 wheel steer (standard)

Axle

- Extendable axles (standard)

Tyres

- Rough terrain foam-filled (standard)

Productivity Options

- Half-mesh platform inserts with swing gate
- Platform top auxiliary rail
- Hostile environment package⁽¹⁾
- Dual axis joystick steering
- Work lights package (2 platform mounted work lights)
- Biodegradable Hydraulic Oil
- Airline to Platform⁽¹⁾
- Anemometer
- Lockable platform control box cover
- Track & Trace⁽²⁾ (GPS unit providing machine location & operating information)
- Operator Protective Structure

Power Options

- AC generator packages (120V/50Hz with dual sockets in platform - 240-415V/50Hz 3 phase with 5 pole 3 phase socket and 240V socket - Both generators are 7,5 kW)
- Cold Weather Package⁽¹⁾
- Diesel scrubber/spark arrestor muffler (catalytic muffler)
- Intake air pre-cleaner



⁽¹⁾ Factory-fit option only

⁽²⁾ Includes a first 2 years subscription

United Kingdom

The Maltings, Wharf Road, Grantham NG31 6BH, T: +44 800 988 3739 (toll free), Fax +44 (0)1476 584334, Email AWP-InfoEurope@terex.com
Visit www.genielift.co.uk/locations to view our global locations list.

Worldwide Manufacturing And Distribution

Australia · Brazil · Caribbean · Central America · China · France · Germany · Italy · Japan · Korea · Mexico · Russia · Southeast Asia · Spain · Sweden · United Arab Emirates · United Kingdom · United States

Product specifications and prices are subject to change without notice or obligation. The photographs and/or drawings in this document are for illustrative purposes only. Refer to the appropriate Operator's Manual for instructions on the proper use of this equipment. Failure to follow the appropriate Operator's Manual when using our equipment or to otherwise act irresponsibly may result in serious injury or death. The only warranty applicable to our equipment is the standard written warranty applicable to the particular product and sale and we make no other warranty, express or implied. Products and services listed may be trademarks, service marks or trade names of Terex Corporation and/or their subsidiaries in the USA and many other countries. Genie is a registered trademark of Terex South Dakota, Inc. © 2017 Terex Corporation.

